

DIAVEL





Index

So good to be bad	4
Unique and unmistakable	6
The engine is king	8
No compromise	9
Unique and distinctive style	11
Touring soul	14
Servicing and maintenance	16
Technical data and equipment	18
Accessories	28
Apparel	34

So good
to be bad

Powerful, muscular, yet also agile for maximum riding pleasure. The Diavel 1260 combines the performance of a maxinaked with the ergonomics of a muscle cruiser. Its design reinterprets Diavel style, giving it a contemporary twist with a line that is both imposing and agile, and which perfectly integrates the 159 HP Testastretta DVT 1262 engine, the beating heart of the Diavel 1260: a bike bold in character with which you will finally feel free to express your personality on the road.





Unique and unmistakeable

The muscular lines and imposing front end give the Diavel 1260 its unique character and personality, while the wide air vents and trellis frame enclose the engine. The rear end, agile and slender, stands out for its unmistakable 240 mm rear tyre. The character of the Diavel 1260 is paramount with the S version, thanks to Öhlins suspension that emphasises the design and enhances the level of performance and riding comfort. Every rider will play a starring role with the Diavel 1260.





The engine is the king

The Testastretta DVT 1262 engine: "The engine is king", as per Ducati tradition. Its 159 HP makes for breath-taking acceleration, while the torque curve, flat and constant already at low revs, ensures continuous and rich delivery that reaches a peak of 13.1 kgm at 7,500 rpm. The advanced electronics ensure maximum riding pleasure in all conditions, while engine character and response can be personalised at any time with the Ride by Wire control combined with the three Power Modes. Active safety is maximised thanks to Ducati Wheelie Control Evo and the Ducati Safety Pack, which includes Cornering ABS Evo and Ducati Traction Control Evo. The Ducati Quick Shift, as standard on the S version, allows for extremely rapid up and downshifting.

No compromise

The Diavel 1260 is a coming together of personality, sportiness and comfort. The trellis frame offers lightness and rigidity, while the fully adjustable 50 mm fork guarantees comfort and precision during sports riding. The combination of a wide handlebar, low seat and central footpegs makes for a low centre of gravity and a comfortable position, facilitating the ride whatever the conditions. The seat, wide and comfortable, easily accommodates two. And on the S version, enjoyment and performance are heightened to the max thanks to Öhlins suspension, with a 48 mm front fork and single rear shock, both fully adjustable, which further enhance the riding experience.

When riding the Diavel 1260, Ducati proposes the Black Rider leather jacket paired with Company jeans, the Black Steel helmet, Downtown technical boots and Logo gloves.

Ducati Apparel Collection designed by **Drudi Performance**





Unique and distinctive style

On the S version, special components and sophisticated details enhance the unique style of the Diavel 1260. Its design is enriched with a dedicated seat, complete with insert bearing the name of the bike, and exclusive wheel rims, cast and machine-processed. The Brembo M50 radial calliper at the front, fully adjustable Öhlins suspension with unmistakable gold finish, and the Ducati Quick Shift up/down all emphasise its sporty nature, while the full LED headlight with Daytime Running Light system ensures the Diavel 1260 S is recognisable at first glance. Also featuring the Ducati Multimedia System for the safe management of calls and music on your smartphone.



Touring soul

The Diavel 1260 is ready to amaze once more as it reveals its touring soul, for dynamism and comfort even on long-range trips. By accessorising the Diavel 1260 with the Touring Pack, or rather semi-rigid side panniers, passenger backrest, windscreen and heated hand grips, you can enjoy the bike's all-round touring spirit. Prepare to be tempted by a new mode of travel, as bold as your Diavel. The adventure you never dared take starts now.



Servicing and maintenance

Safety as standard

The continuous work that Ducati carries out in terms of design, research and development serves to ensure cutting edge bikes characterised by maximum active safety levels. A commitment that involves the definition of increasingly advanced technological systems to increase the rider's level of control, such as the Ducati Safety Pack (DSP) that, for Diavel 1260, includes ABS Cornering Evo and Ducati Traction Control (DTC).

More value to your passion

With Ever Red, the quality and reliability of the Ducati brand remain your inseparable travelling companions over time. Ever Red is the exclusive Ducati warranty extension programme. With its activation you can continue to feel protected for 12 or 24 months beyond the expiration of the Ducati Warranty (24 months). Ever Red includes roadside assistance for the entire coverage period and no mileage limits. In this way you can ride for all the kilometres you want, even abroad, enjoying your Ducati without any worries.

To find out if the Ever Red extension is available in your country and for further information contact your Ducati dealer or visit ducati.com.

Endless excitement

In designing each bike, Ducati constantly strives to ensure maximum reliability while reducing service costs. A commitment that has seen the intervals for the main Desmo Service, in which valve clearance is checked and adjusted if necessary, to be extended to 30,000 km for the Diavel 1260.

Even the simplest of checks, such as the Oil Service, are extended to 15,000 km or 12 months. A considerable interval for such high performance engines, which only confirms the high quality standards adopted in terms of material selection and R&D processes. Ducati continuously invests in the technical training of its dealers.

The specific skills offered by the official Ducati Service network ensure that all those operations needed to keep every Ducati in perfect condition are thoroughly executed, while advanced equipment such as the Ducati Diagnosis System allows the software on each Ducati to be updated with the latest releases, ensuring that the electronics continue to perform at the maximum level.

Always by your side

One of Ducati's main goals is to offer every Ducatista the chance to enjoy unlimited and safe travel all over the world. To achieve this aim, Ducati offers a "fast delivery" original spares service, with delivery in 24/48 hours across 85% of the areas in which it operates. With a distribution network that covers more than 86 countries, thanks to 718 official Dealers and Service Points*, choosing a Ducati means you can travel worry free and in total freedom, wherever the road may take you, and count on support from our extensive Dealer network that ensures Ducati quality and professionalism is always close at hand.

718 Authorised dealers and service points

86 World countries

*Information updated as of July 2019



Ever Red
Extended Warranty



*Equal to 18,000 miles.



Technical data and equipment



DIABLO 1260

Dimensions

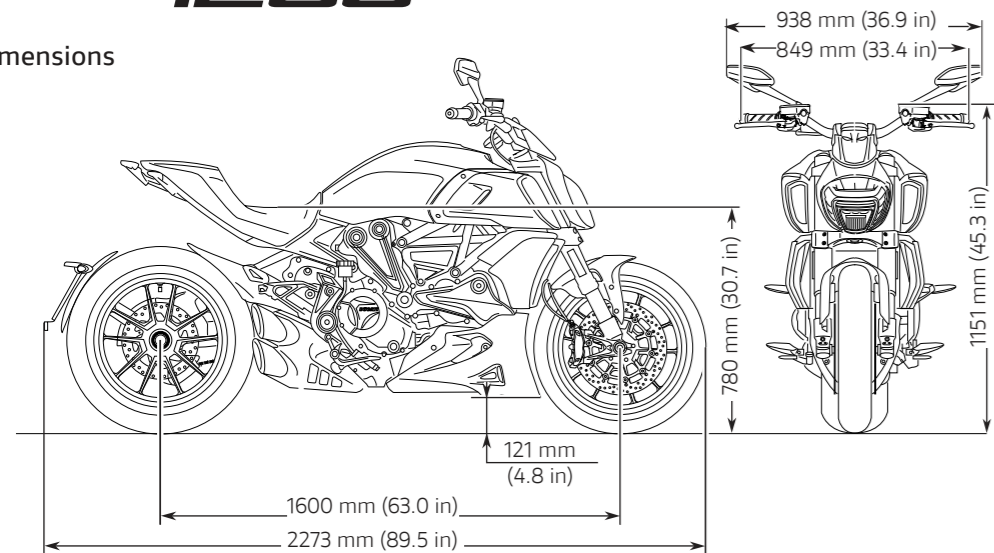

Engine

Engine	Ducati Testastretta DVT 1262, L-Twin cylinder, 4 valves per cylinder, Dual Spark, Liquid cooled, Desmodromic Variable Timing
Displacement	1,262 cc (77.0 cu in)
Bore X stroke	106 x 71.5 mm
Compression ratio	13.0 : 1
Maximum power	159 hp (117 kW) @ 9,500 rpm
Maximum torque	95 lb-ft (129 Nm, 13.1 kgm) @ 7,500 rpm
Fuel injection	Electronic fuel injection system, Øeq 56 mm elliptical throttle bodies with Ride-by-Wire system
Exhaust	Stainless steel pipes and single muffler with twin tail pipes, Catalytic converter and 2 lambda probes

Transmission

Gearbox	6 speed
Primary drive	Straight cut gears, Ratio 1.84:1
Ratio	1=37/15, 2=30/17, 3=27/20, 4=24/22, 5=23/24, 6=22/25
Final drive	Chain, Front sprocket Z15, Rear sprocket Z43
Clutch	Slipper and self-servo wet multiplate clutch with hydraulic control

Chassis

Frame	Tubular steel trellis frame
Front suspension	Ø 50 mm adjustable usd fork
Front wheel	Light alloy cast 3.5"x17"
Front tyre	Pirelli Diablo Rosso III 120/70 ZR17
Rear suspension	Monoshock, preload and rebound adjustable, Aluminium casted single-sided swingarm
Rear wheel	Light alloy cast 8.0"x17"
Rear tyre	Pirelli Diablo Rosso III 240/45 ZR17
Wheel travel (front/rear)	120 mm / 130 mm (4.7 in / 5.1 in)
Front brake	2 x Ø 320 mm semi-floating discs, Radially mounted Brembo monobloc 4-piston M4.32 callipers, PR18/19 radial master cylinder, Cornering ABS Evo
Rear brake	Ø 265 mm disc, 2-piston Brembo floating calliper, Cornering ABS Evo
Instrumentation	3.5" TFT colour display and dedicated warning light display

Dimensions and Weights

Dry weight	218 kg (481 lb)
Kerb weight	244 kg (538 lb)
Seat height	780 mm (30.7 in)
Wheelbase	1,600 mm (63.0 in)
Rake	27°
Front wheel wtrail	120 mm (4.7 in)
Fuel tank capacity	17 l (4.5 US Gal)
Number of seats	2

Standard Equipment

Riding Modes, Power Modes, Ducati Safety Pack (Cornering ABS Evo, Ducati Traction Control Evo DTC), Ducati Wheelie Control Evo (DWC), Cruise control, Ducati Power Launch Evo (DPL), Hands-Free, Backlit handlebar switches, 3.5" TFT colour display, Full LED lighting system, Self cancelling turn indicators. Ready for: Ducati Quick Shift up/down Evo (DQS), Ducati Multimedia System (DMS), Antitheft system

Warranty

24 months, Unlimited mileage

Maintenance

Maintenance service intervals 15,000 km (9,000 miles) / 12 months

Maintenance

Valve clearance adjustment 30,000 km (18,000 miles)

Emissions & Consumption*

Standard	Euro 4
CO₂ Emissions	128 g/km
Consumption	5.4 l/100 km



Equal to 18,000 miles.

In USA, Canada and Mexico fuel tank capacity is 16 l (4.2 US gal) and maximum power is 157 hp (116 kW) @ 9,250 rpm.

* Only for countries where the Euro 4 standard applies.

DIAVEL 1260S

	Diavel 1260	Diavel 1260 S
Front Suspension	Ø 50 mm fully adjustable usd fork	Ø 48 mm Öhlins fully adjustable usd fork, TiN treatment
Rear Suspension	Monoshock, preload and rebound adjustable	Öhlins fully adjustable monoshock,
Seat	Standard	Premium
Front Brake	Radially mounted Brembo monobloc 4-piston M4.32 callipers, PR18/19 radial master cylinder	Radially mounted Brembo monobloc 4-piston M50 callipers, PR16/19 radial master cylinder
Wheels	Cast	Cast and machined
Daytime Running Light (DRL)	-	Standard*
Ducati Quick Shift up/down (DQS)	Accessory	Standard
Ducati Multimedia System (DMS)	Accessory	Standard

* Please contact your dealer for information on availability.



1 Fully adjustable front and rear Öhlins suspension with golden finish



2 Exclusive cast and machine-processed rims



3 Premium seat with Diavel insert

DIAVEL 1260

Sandstone Grey



Dark Stealth



DIAVEL 1260S

Ducati Red



Dark Stealth & Thrilling Black



Accessories

To enhance riding pleasure, numerous accessories have been created, all embodying that blend of sportiness, elegance and comfort for which this bike stands out. To express the various facets of its personality, Ducati has designed and created three packages: Sport, Touring and Urban. Machined from solid aluminium and carbon details come together in the Sport package, which aims to enhance the powerful and muscular character of the Diavel 1260. For those who want to travel in comfort, whether alone or in two, the Touring package allows you to fully enjoy the bike's cruiser skills and be comfortable even when not riding. The Urban package boasts a strong and refined style, thanks to precious machined from solid aluminium details that highlight a unique and irreverent elegance.



For more information about the Ducati Performance range, tech specs and instructions, refer to a Ducati Dealer or visit the Accessories section of the ducati.com website





1 Set of semi-rigid side panniers

2 Passenger rear backrest



 3 Smoked Sport Headlight Fairing





4 Complete exhaust assembly



5 Carbon front mudguard





6 Billet aluminium sprocket cover





1 Premium seat



2 Billet aluminium rearview mirrors

OK A ■ ■



3 Covers for brake and clutch fluid reservoirs

A



4 Billet aluminium tank cap

A



5 Brake lever

A

Apparel

Black Rider
Leather jacket

Company C3
Technical jeans

Reflex Attitude
Short-sleeved polo shirt

Maui
Sunglasses



Ducati Apparel Collection designed by **Drudi Performance**





Black Steel
Full-face helmet

Downtown C1
Leather jacket

Logo C1
Leather gloves



Key to symbols

 For racing use only - The product marked with this symbol can only be used on competition vehicles. Use outside a competition track of motorcycles equipped with this product is prohibited by law. Verify any further restrictions with the relevant race course. Motorcycles equipped with this accessory are prohibited from operating on public roads.

 This accessory is not approved for road circulation

 This accessory is approved for road circulation in Europe

 This accessory cannot be used/sold in Japan

 This product is intended for vehicles used only in closed-course competition. Operation on public roads is prohibited by law.

 Anodized

 Black

 Matt

 Silver

 Tinted



ducati.com

Riding a motorcycle is the most exciting way to enjoy the road, and offering the utmost safety to the motorcyclist is Ducati's commitment. Ducati bikes are increasingly easy to handle, reliable and better equipped to guarantee maximum safety and enhance riding pleasure. Technical clothing is made with more and more advanced materials for adequate protection and increased visibility. The safety of motorcyclists is Ducati's commitment. For more information visit the safety section of the Ducati site (www.ducati.com).

Warning: The photos and technical information in this catalogue may refer to prototypes subject to modifications during production and are purely for illustration and reference purposes, and are therefore not binding on Ducati Motor Holding S.p.A. Sole Shareholder Company - Company subject to the direction and coordination of AUDI AG ("Ducati"). Ducati cannot be held responsible for any print and/or translation errors. This catalogue is transnational and therefore some products may not be available and/or their features may vary in accordance with local laws. Not all colours and versions are available in each country. Ducati reserves the right to make changes and improvements to any product without obligation of prior notice or to make such changes to products already sold. Further characteristics of the products are contained in the pertinent owner's manuals. The products represented are not definitive versions and are therefore subject to significant changes at Ducati's discretion without prior notice. The photographs published in this catalogue show only professional riders under controlled street conditions. Do not attempt to imitate such riding behaviour as it could be dangerous for you or other people on the road. This catalogue, including but not limited to the trademarks, logos, texts, images, graphics and table of contents herein, constitute Ducati intellectual property, or in any event Ducati has the right to reproduce it; any reproduction, modification or other whole or partial use of the catalogue or its contents, including publication on the Internet without the prior written consent of Ducati, is prohibited.

Actual fuel consumption may vary based on many factors, including but not limited to riding style, maintenance performed, weather conditions, surface characteristics, tyre pressure, load, weight of the rider and the passenger, accessories.

Ducati indicates the dry weight of the motorcycle excluding battery, lubricants and coolants for liquid-cooled models. The weights in running order are considered with all operating fluids, standard equipment and the fuel tank filled to 90% of its useful capacity (UE regulation no. 168/2013). For more information visit www.ducati.com. November 2019.



WDW2020
WORLD DUCATI WEEK
17 - 19 Luglio / Misano, Italia
wdw.ducati.com

Developed with



Technical partner

